

## How do two or more penetration gages yield different measurements in the same recess?

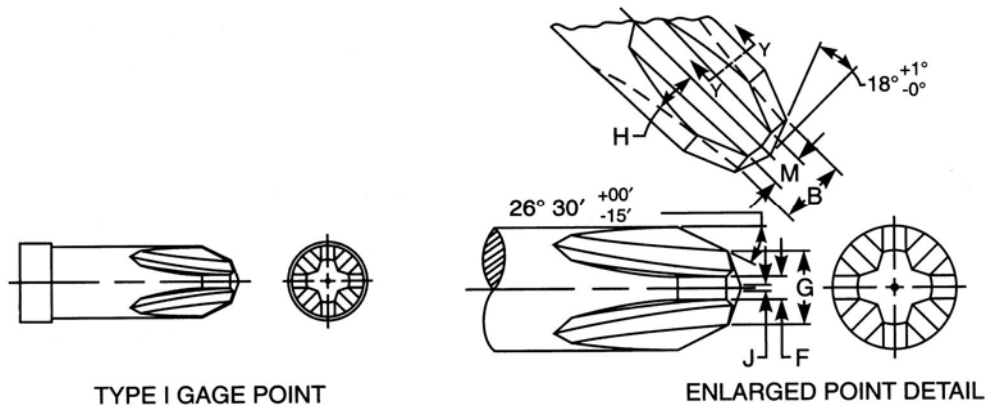

All properly designed and calibrated gages of the same type and size should provide those using the gages very similar values when measuring the same part or parts. When this does not occur the user should examine the gages to determine why they are providing different measurement results.

For many years I have been involved in situations where two or more Phillips (ASME Type I) penetration gages provided different measurement results when measuring the same screw's recess. I was first involved in this as a screw manufacturer, then as a supplier of recess heading punches, later as a Phillips penetration gage supplier, and finally as an ISO 17025 (A2LA) accredited calibration laboratory owner.

It was not until becoming an accredited calibration laboratory owner that I finally learned what the source of these recess measurement discrepancies is. Phillips recess measurement discrepancies are the result of penetration point elements that have different degrees of point geometry wear. The applicable specification for Phillips penetration points is the American Society of Mechanical Engineers (ASME) standard B18.6.4.

In our calibration laboratory we discovered that until very recently most Phillips penetration gage users assumed that the gage was completely calibrated if the indicator travel measured correctly and the indicator was set at "0.000" by fully depressing the point into the gage body. After calibrating hundreds of Phillips penetration points to the ASME B18.6.4 standard, our laboratory personnel learned that the biggest contributor to Phillips recess measurement disagreements has been that one or more of the penetration gages used in the measurement comparison were worn out of specification limits.

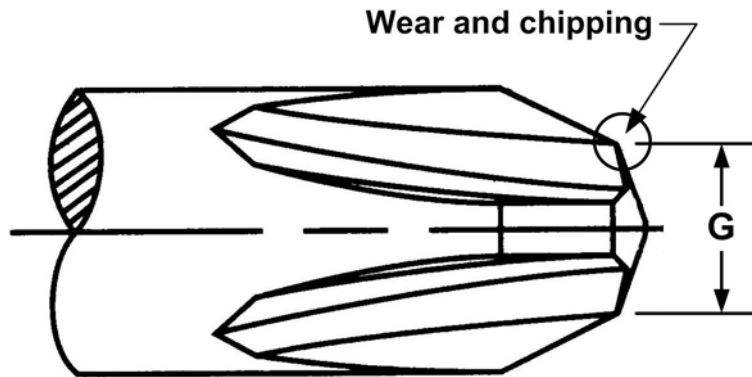

Through our calibration work and data analysis we have discovered that close to one half of the Phillips penetration points we calibrate are either chipped or worn so that the “G” dimension is no longer within the specification limits. When looking at the drawing this makes perfect sense. The boundaries of the “G” diameter are made by the intersecting of the angle on the penetration element’s extreme end and the outer angle on the point element’s wings. This is the location that actually comes in contact with the screw’s recess every time the element is used to determine a screw recess’s penetration depth.

After many uses of a penetration gage, the sharp corner created by the intersection of these two angles on the element loses its sharp edge and becomes rounded or chipped making the “G” dimension larger. Eventually the “G” dimension will wear beyond the specification limits. As the intersection of these angles on the penetration point element wears, the element yields increasingly deeper measurements when measuring the same recess. When comparing the measurements from two penetration gages, the one consistently yielding deeper measurements will have more point wear than the one yielding consistently shallower measurements. If two penetration gages yield measurements further apart than .002 inches, the point measuring consistently deeper should be calibrated to determine if it is still within the applicable specified dimensional limits.

We have learned that similar wear on the points of penetration elements for POZIDRIV™ (ASME Type 1A), square, hex, and 6 Lobe recesses has the same affect of yielding deeper penetration readings than do elements with sharp edges on their outer contact edges.

Fastener suppliers that want to avoid penetration measurement disparities among their own gages, and between their gages and those of their customer, should have all of their penetration points properly calibrated as indicated by the applicable specifications on a calibration cycle no longer than one year.