



100%

The path to shipping
“**ZERO DEFECT PARTS**”

and

The role of +/- 6 Sigma

Presented by

Joe Greenslade

Greenslade & Company, Inc.

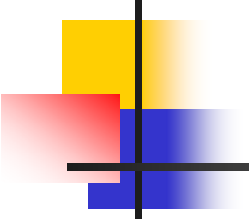

Fasteners are different. You know you cannot.....

- head parts at 500 parts per minute.
- roll parts at 1000 parts per minute.
- head slot parts burr-free.
- coat parts to have 1000 hours of salt spray resistance.
- make a complete header change-over in less than an hour.
- make SPC work in fastener manufacturing.

Fasteners are different.

Everyone know you cannot.....

- ship “**ZERO DEFECT PARTS**” in production quantities!



Problem is....customers are
demanding “ZERO DEFECT PARTS”.

The question is no longer,
“Can you ship ZERO DEFECT
PARTS?”

Now the question is,
“When are you going to start
shipping ZERO DEFECT PARTS?”



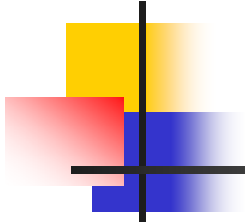

The only path to
“ZERO DEFECT PARTS”
is based on the **prevention**, not
the detection **of defects.**



The use of **statistics** is a major factor in achieving “**ZERO DEFECT PARTS**”.

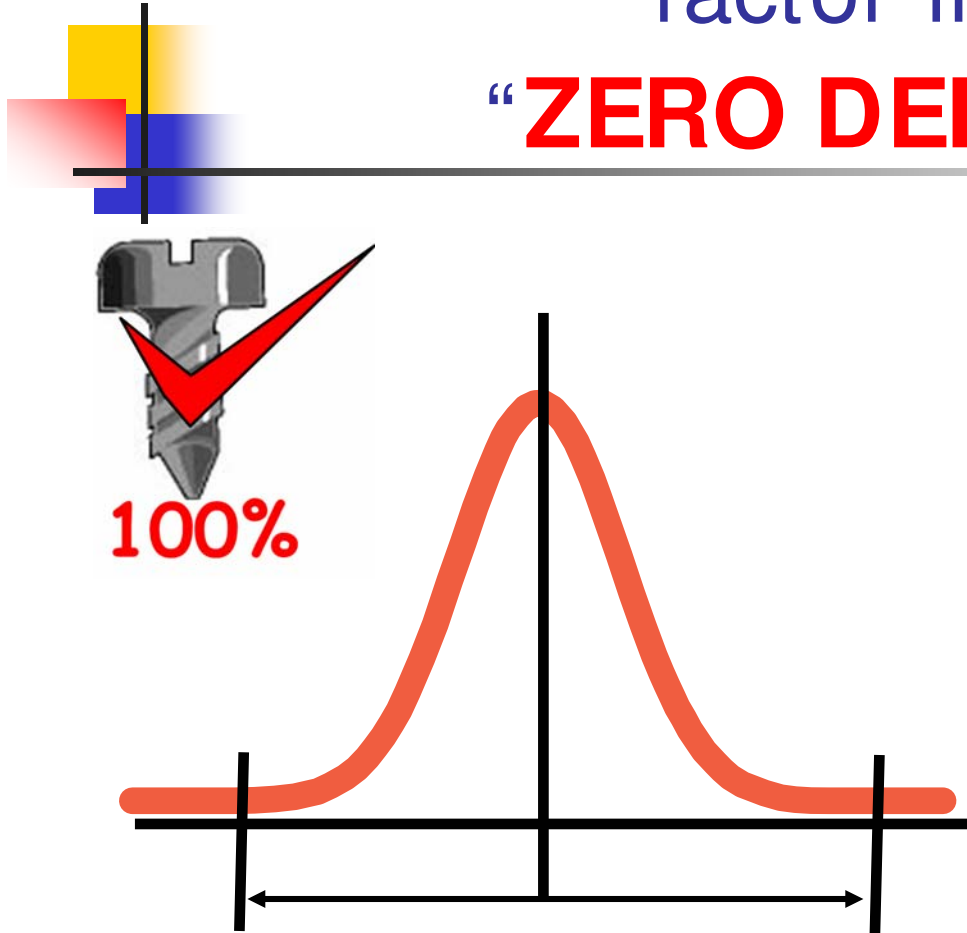

- Average or Mean
- Range
- Standard deviation or Sigma

Sigma = Standard Deviation

-a measurement of variation-

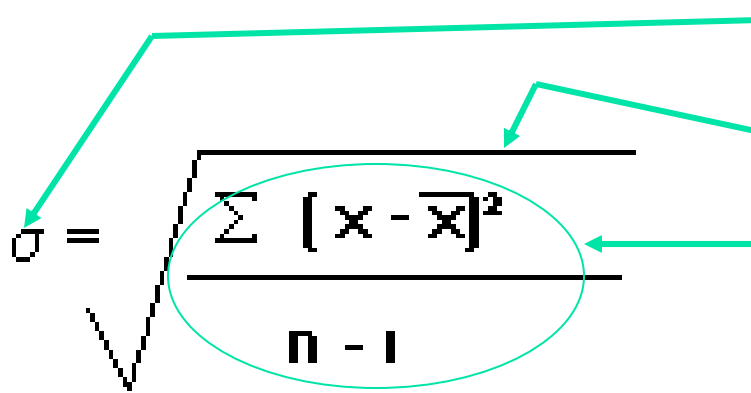

The diagram shows the formula for standard deviation: $\sigma = \sqrt{\frac{\sum (x - \bar{x})^2}{n - 1}}$. A green oval highlights the denominator $n - 1$. Three green arrows point from the text on the right to the formula: one points to the sigma symbol, one points to the square root symbol, and one points to the numerator $\sum (x - \bar{x})^2$.

$$\sigma = \sqrt{\frac{\sum (x - \bar{x})^2}{n - 1}}$$

- **Sigma (std. dev.) equals**
- The square root of
- The sum of the differences of the sample values minus the average of all of the samples, divided by the total number of samples minus one.

**Specification:
.240 - .260**

Three sample
lots measuring
the same feature.

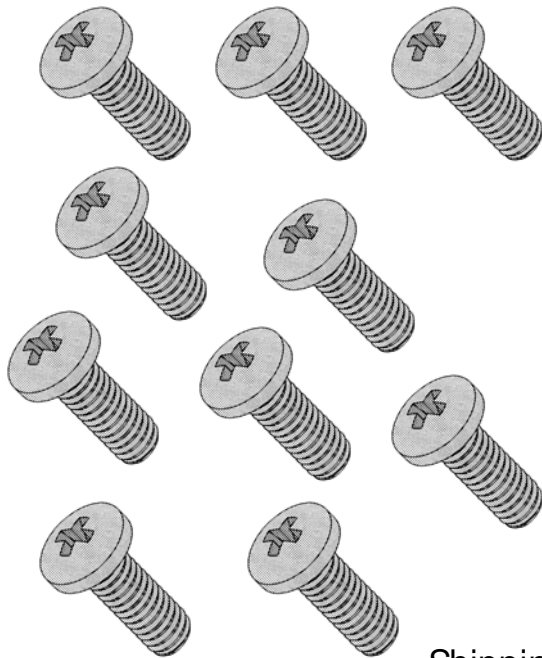

Samples	Wide Variation	Medium Variation	Tight Variation
1	.241	.251	.251
2	.259	.250	.250
3	.256	.248	.249
4	.252	.252	.252
5	.248	.249	.248
6	.245	.253	.252
7	.257	.250	.250
8	.252	.251	.251
9	.248	.247	.248
10	.259	.253	.252
Average	.252	.250	.250
High	.241	.253	.252
Low	.259	.247	.248
Range	.018	.006	.004

Wide variation in sample - All within specification

- Spec: .240 - .260
- 10 samples
- High .259
- Low .241
- Range .018
- Average .250
- **Sigma .006**
- **+ / - 6 sigma
.216 - .288**

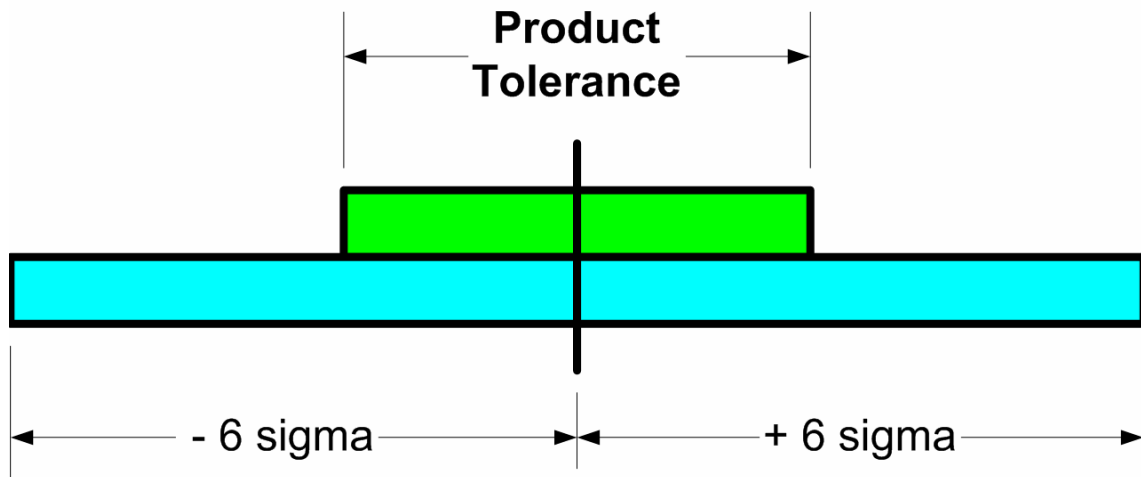

Medium variation in sample - All within specification

- Spec: .240 - .260
- 10 samples
- High .253
- Low .247
- Range .006
- Average .250
- **Sigma .002**
- **+ / - 6 sigma**
.238 - .262

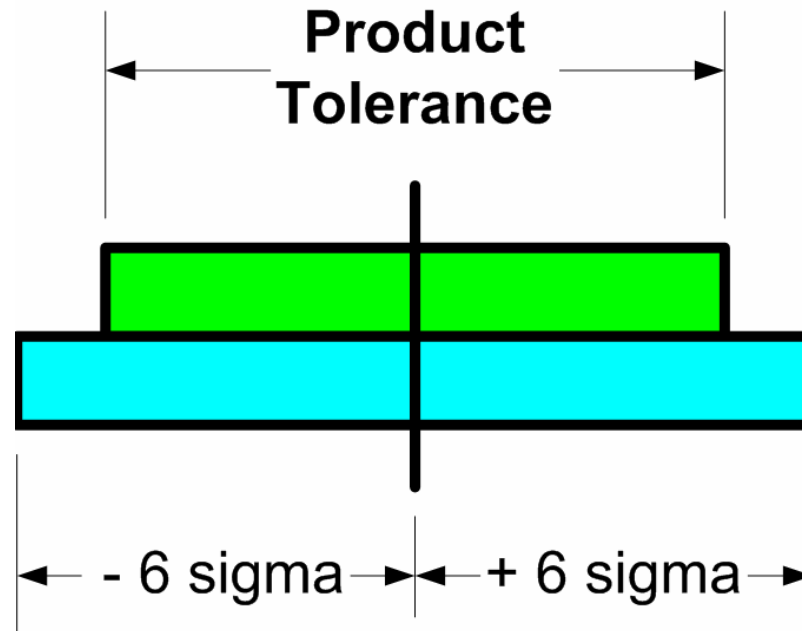

Small variation in sample - All within specification

- Spec: .240 - .260
- 10 samples
- High .252
- Low .248
- Range .004
- Average .250
- **Sigma .0016**
- **+ / - 6 sigma**
.241 - .259

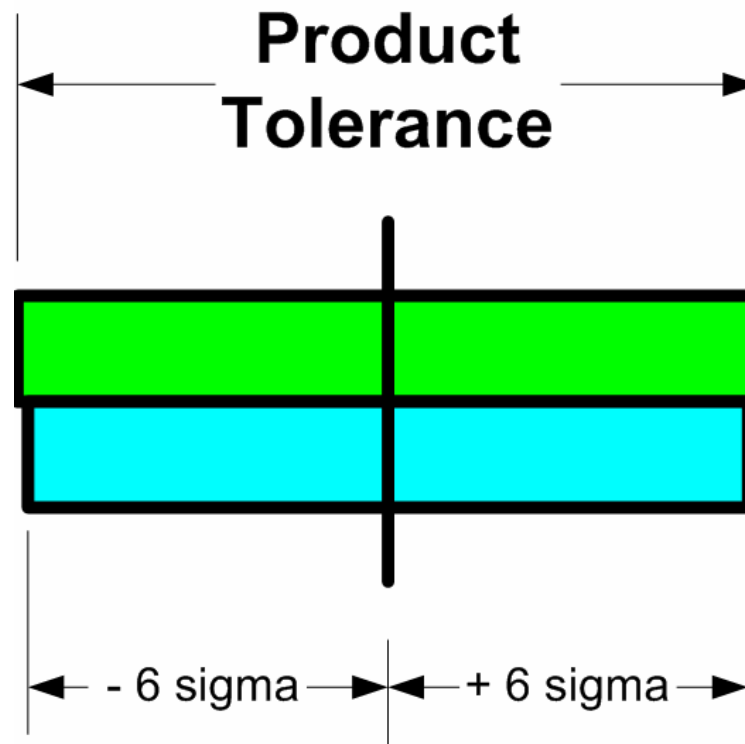



Sigma predicts outcomes based on the values of samples

- If the average value of the sample lot **+ / - 6 sigma** (std. dev.) falls within the tolerance limits.....
the **defective parts per million** within the entire manufacturing lot will be **3.4 or less!**
- If + / - 6 sigma cannot be achieved, the closer you get the fewer defects you will produce.

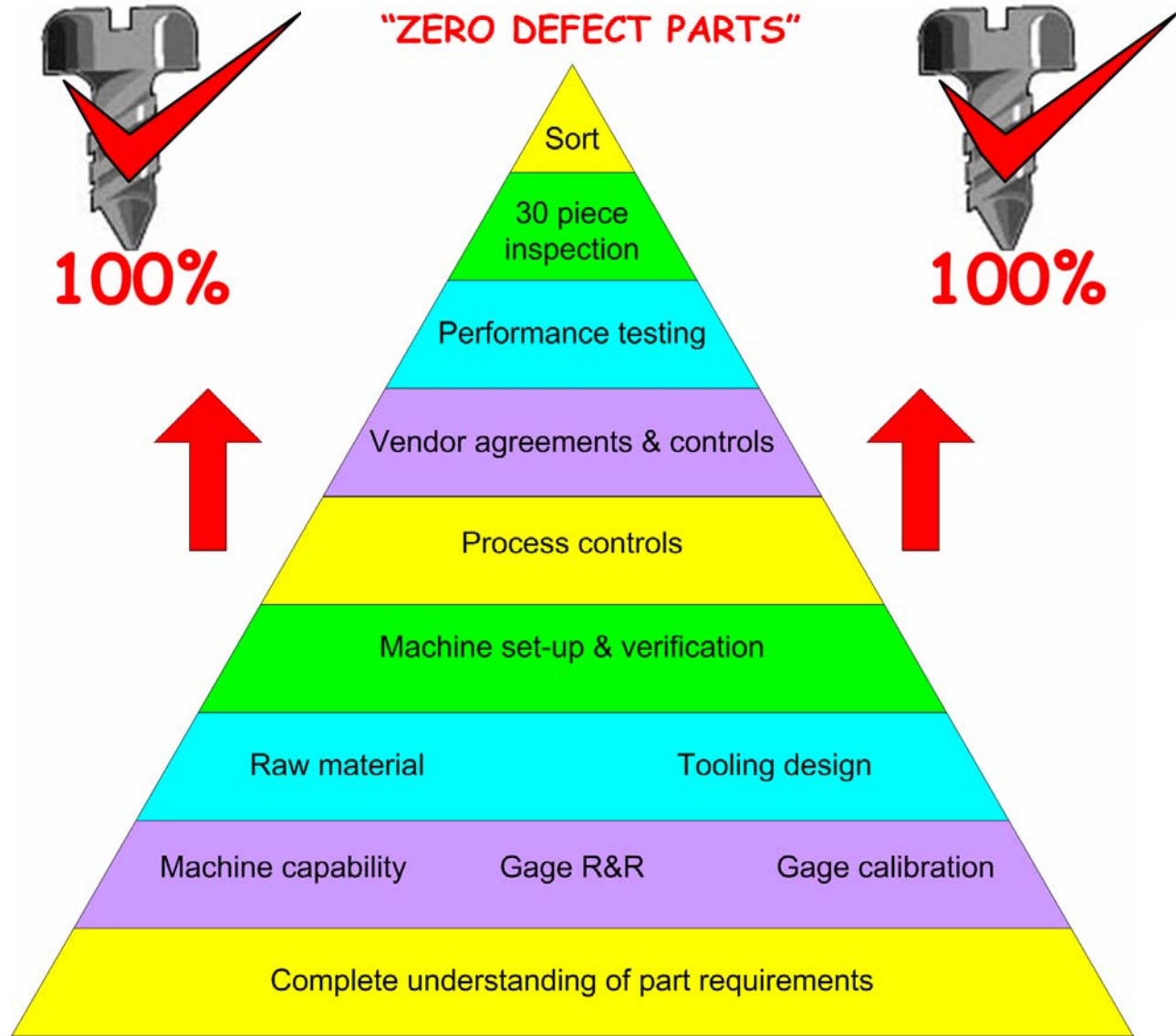

The path to shipping **"ZERO DEFECT PARTS"**

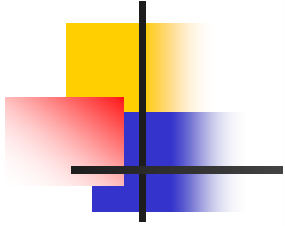

"ZERO DEFECT PARTS"

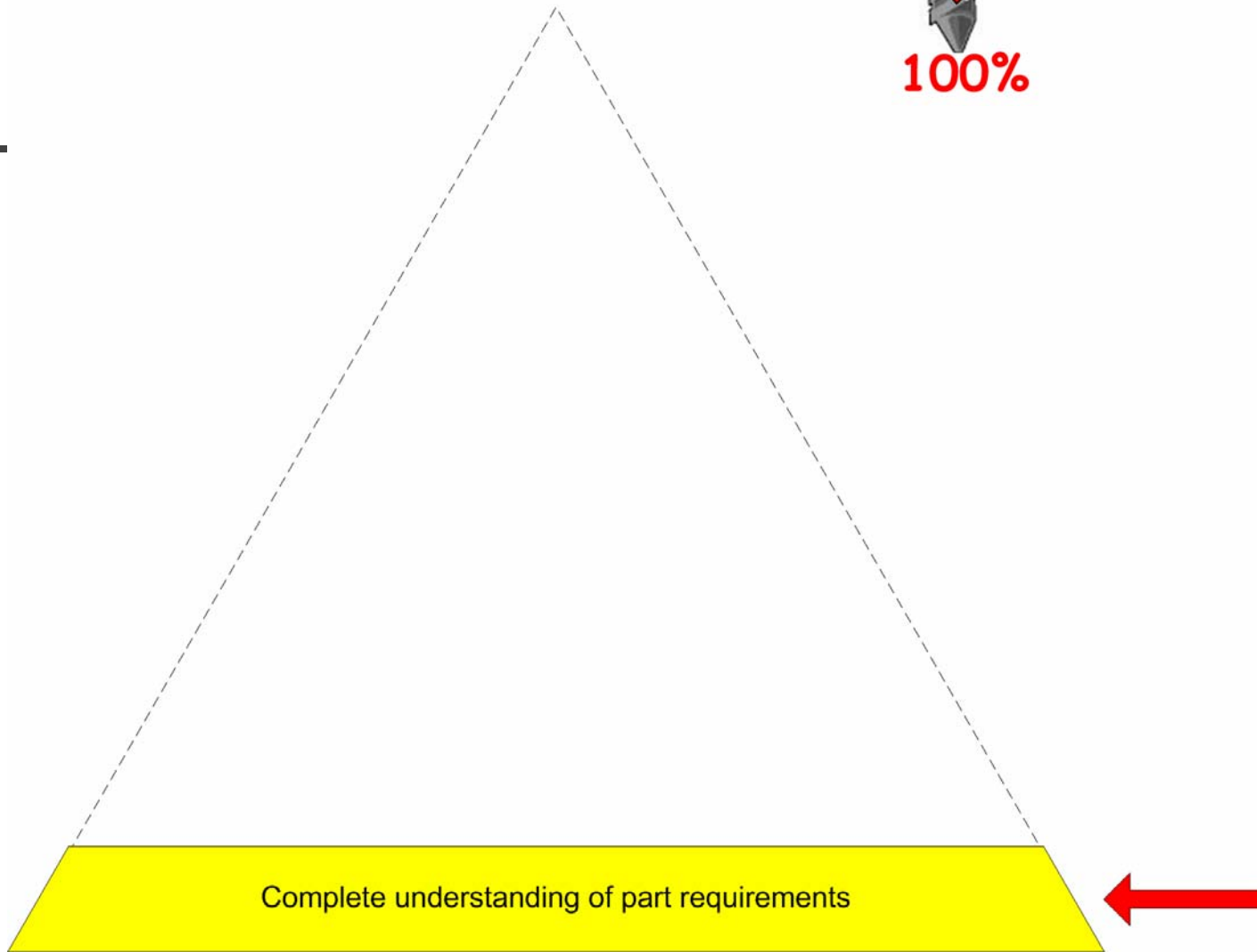

Incomplete understanding - poor chance for success!

- What are the “**mission critical**” product characteristics for the customer?

- Recess quality?
- Thread fit?

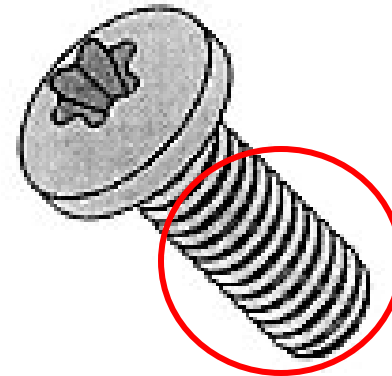

- Straightness?
- ????????????

Incomplete understanding - poor chance for success!

- Drawings and specifications:
 - Dimensions & geometric tolerances?
 - Physical requirements?
 - Performance requirements?

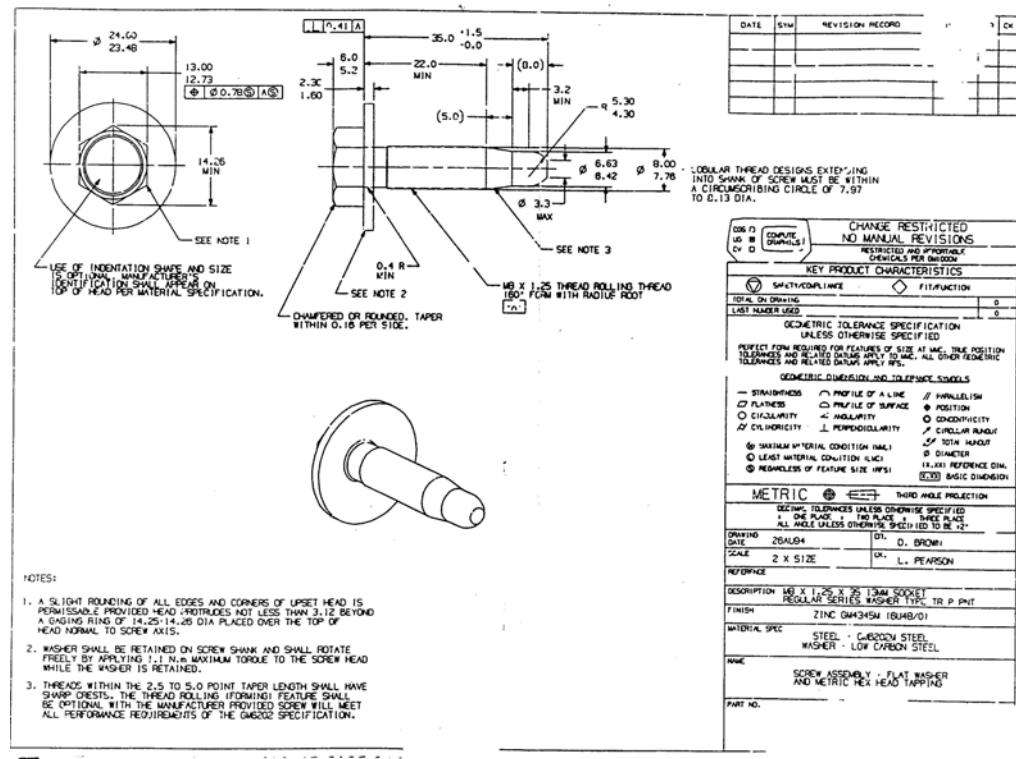

Incomplete understanding - poor chance for success!

- **Correlation** of testing methods and acceptance criteria?

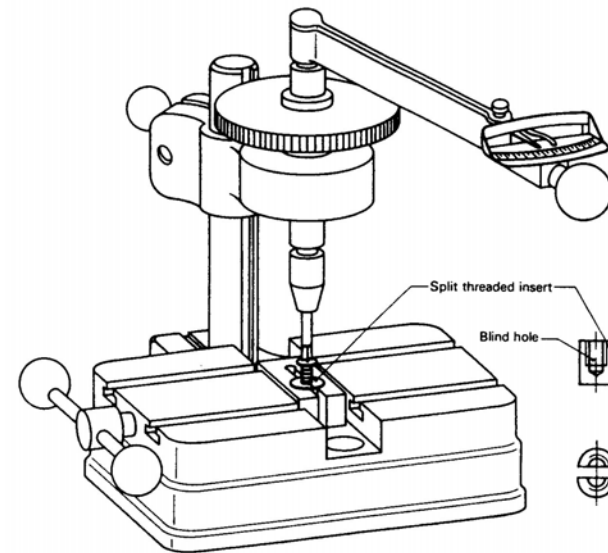
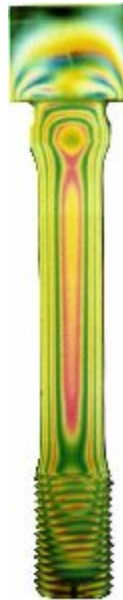

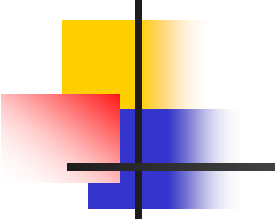

"ZERO DEFECT PARTS"

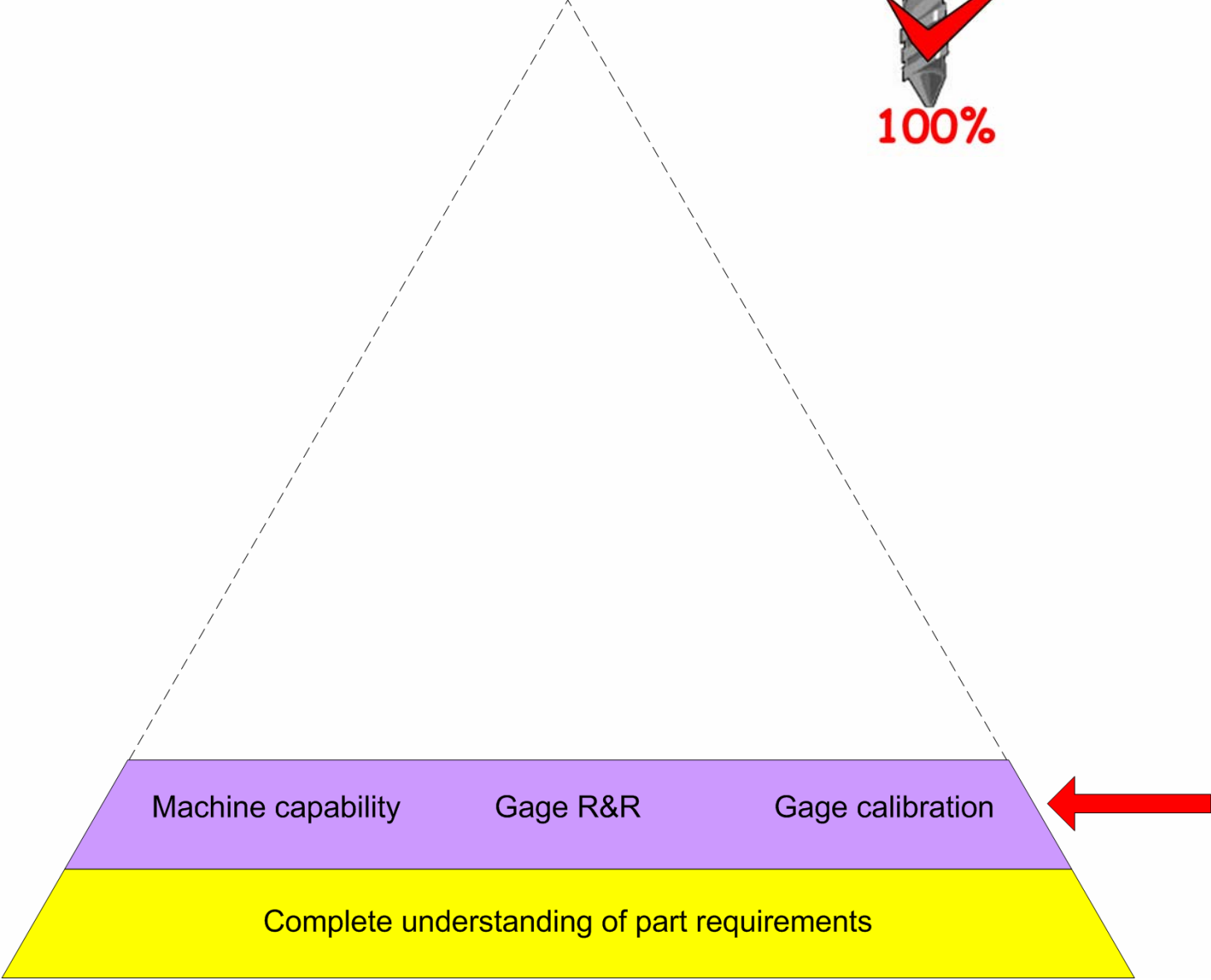

Machine Capability

- The **C_p** target should be **2.00**.
- This will yield not more than **3.4** discrepant parts per million.
- This is **+ / - 6 Sigma**.



Higher Cp (process capability)

is likely to produce fewer defective parts.

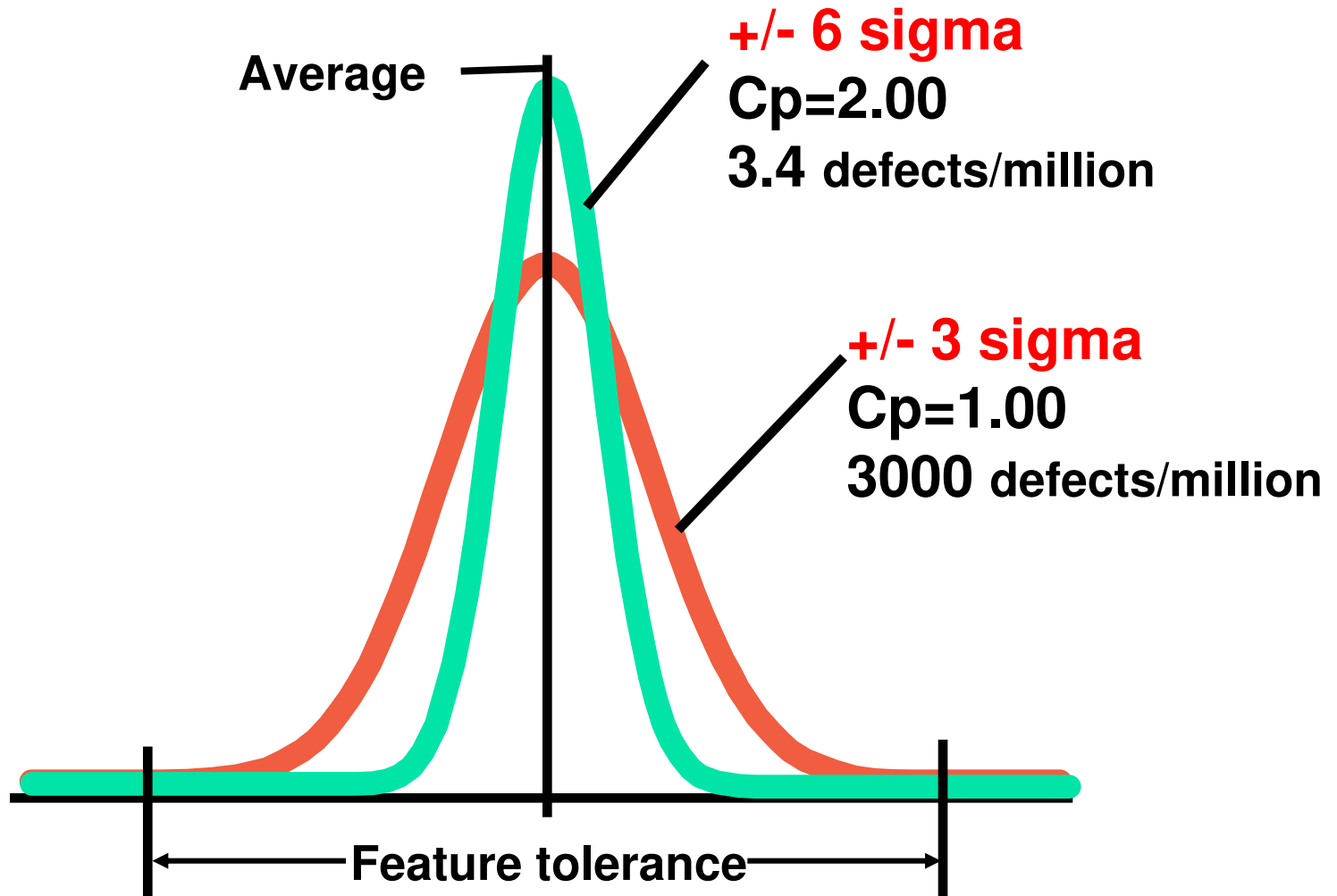
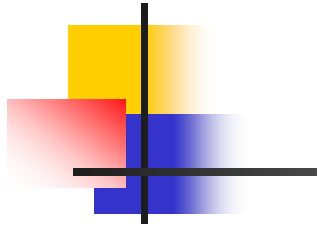

WARNING!

- Old, cheap gaging technology will **NOT** get you to ZERO DEFECT PARTS!

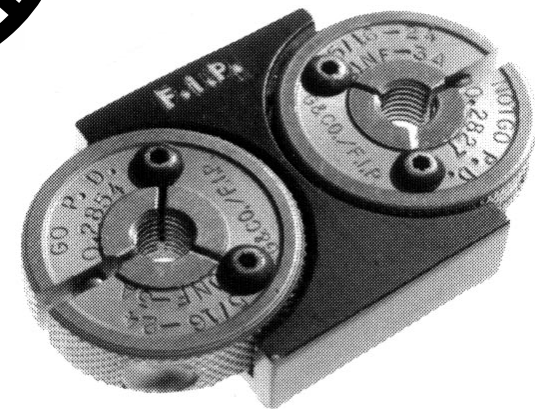
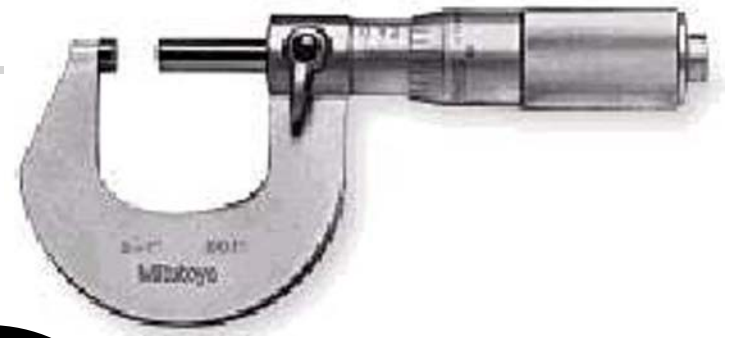

Gages must have low GR&R!

- Where possible, **gages** should be **variable**, instead of fixed limit.
- The **target** Gage Repeatability and Reproducibility (**GR&R**) should be **10%**.



Gage calibration is critical!

- Strict adherence is critical:
 - **Traceability**
 - **Recognized calibration practices**
 - **Calibration frequency**



Gage calibration is critical!

- Use outside calibration laboratories that are accredited to **ISO 17025** by internationally recognized bodies.



**American Association of Laboratory Accreditation
Registration Number 1032.01**

Gage calibration is critical!

You can make all of the measurements you are supposed to, when you are supposed to, and every measurement can appear compliant, but

.....



Gage calibration is critical!

.....if the gage is not properly calibrated, every single part might actually be **NON-COMPLIANT!**



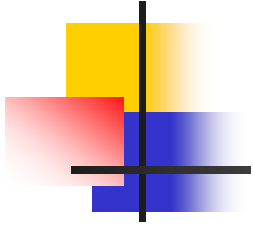

"ZERO DEFECT PARTS"

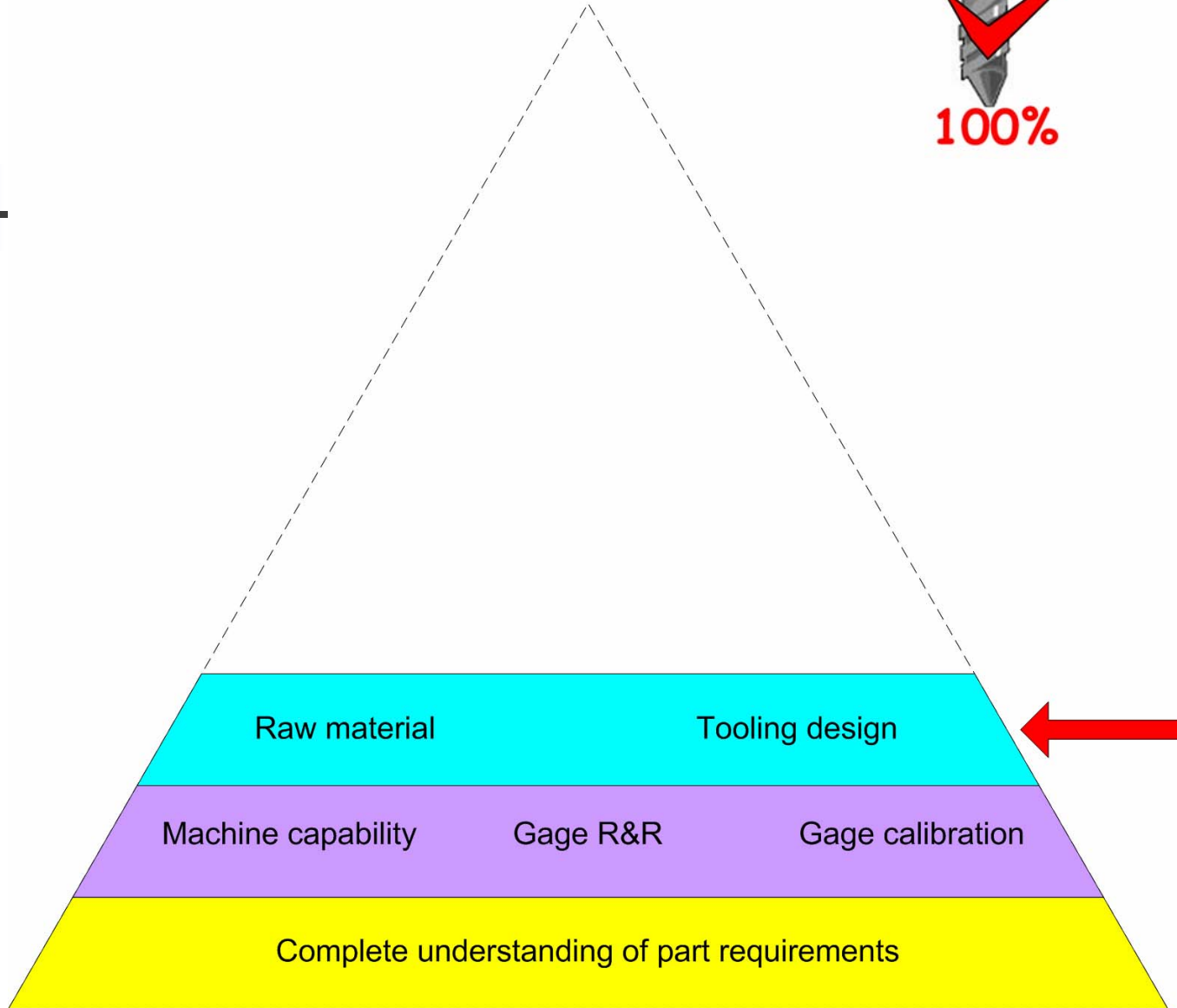

Consistent material-consistent parts!

- Thoroughly defined requirements
 - Chemistry
 - Dimensions
 - Coating
- **Single vendor** with registered ISO 9000 quality system.

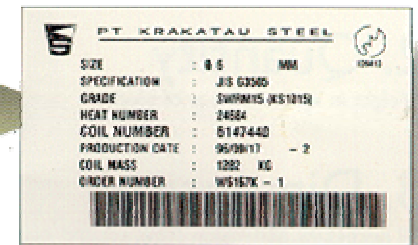
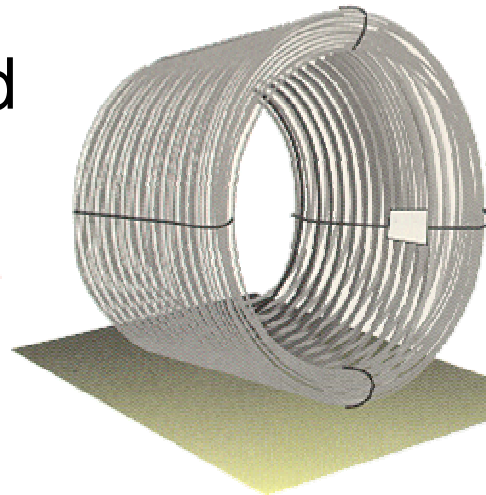

**ISO 9002
CERTIFIED**

Consistent tooling-consistent parts!

- Computer modeling of tooling design can increase tool life.
- Scientific Forming Technologies Corp.
John Walters
614-451-8323

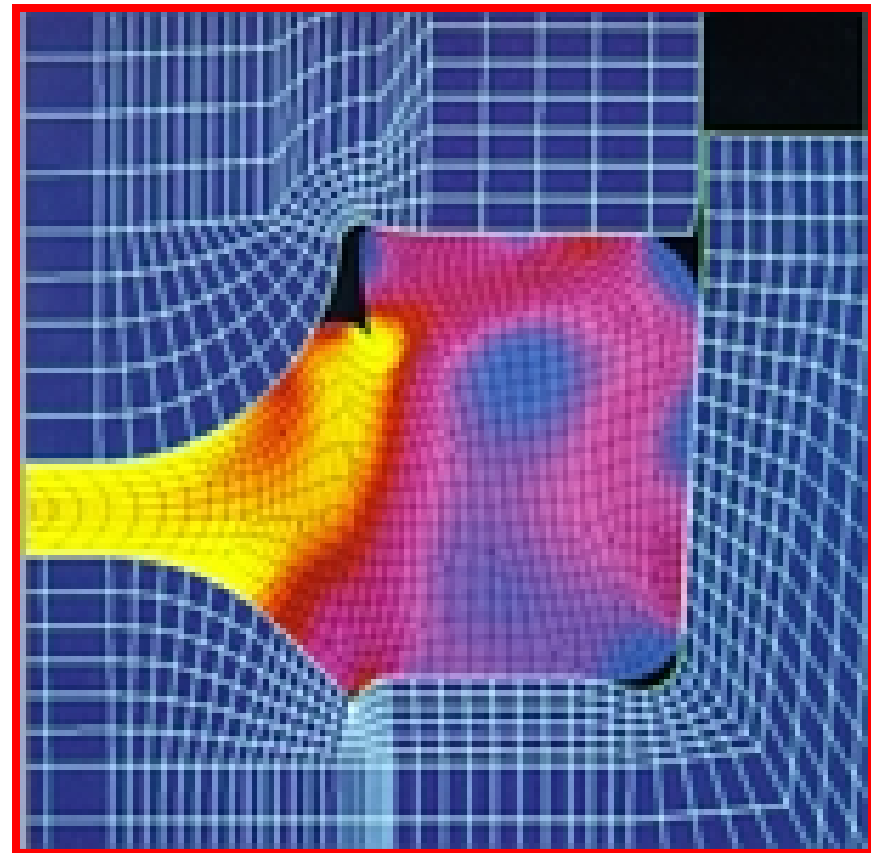

Consistent tooling-consistent parts!

- Tooling material selection
 - Carbide where possible (grade?)
 - Titanium nitride coated tool steels
- **Single vendor** with ISO 9000 registered quality system



**ISO 9002
CERTIFIED**

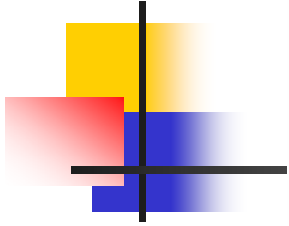

"ZERO DEFECT PARTS"

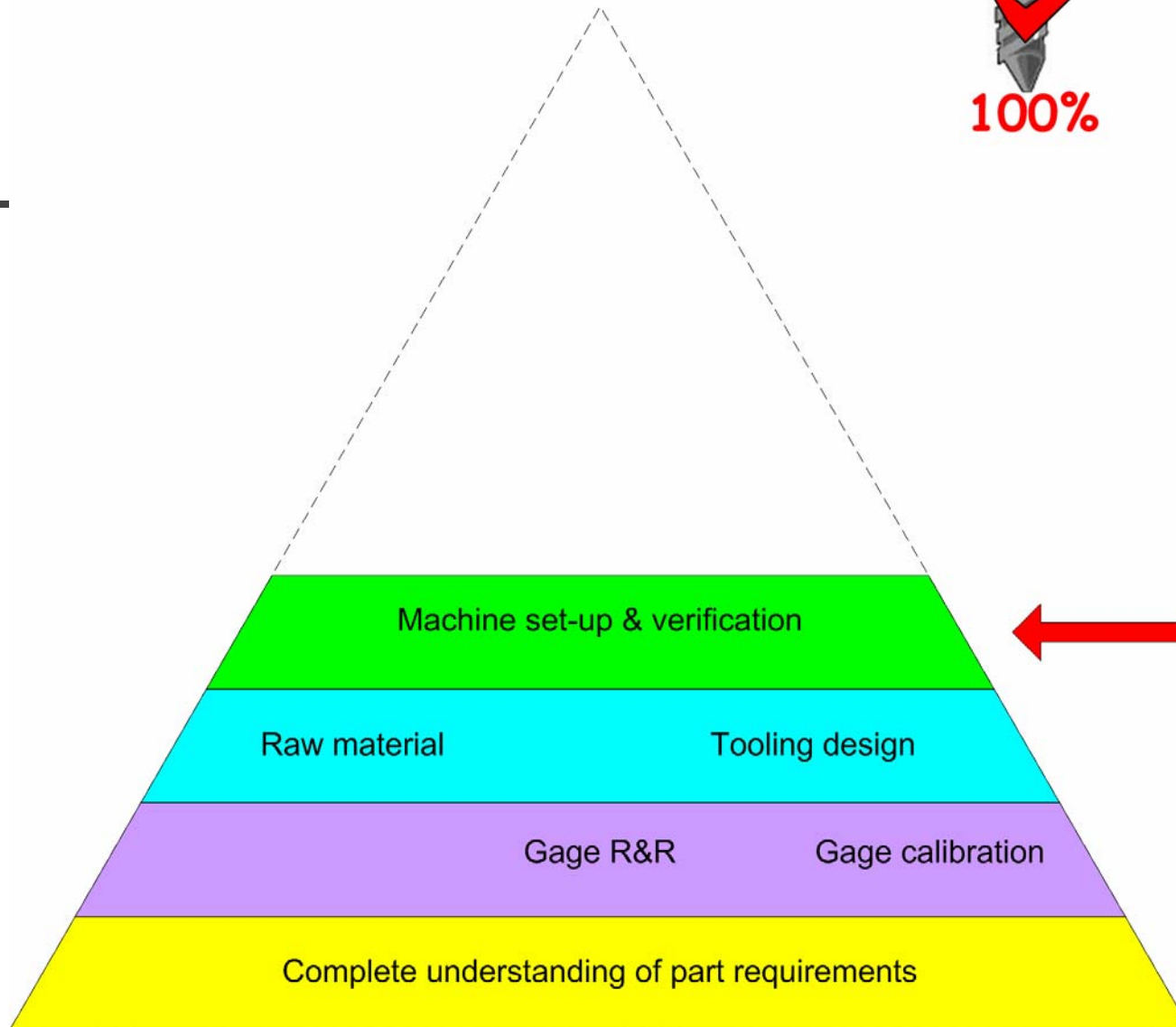

Start with conforming parts to yield conforming parts!

- Two sets of eyes are safer than one!

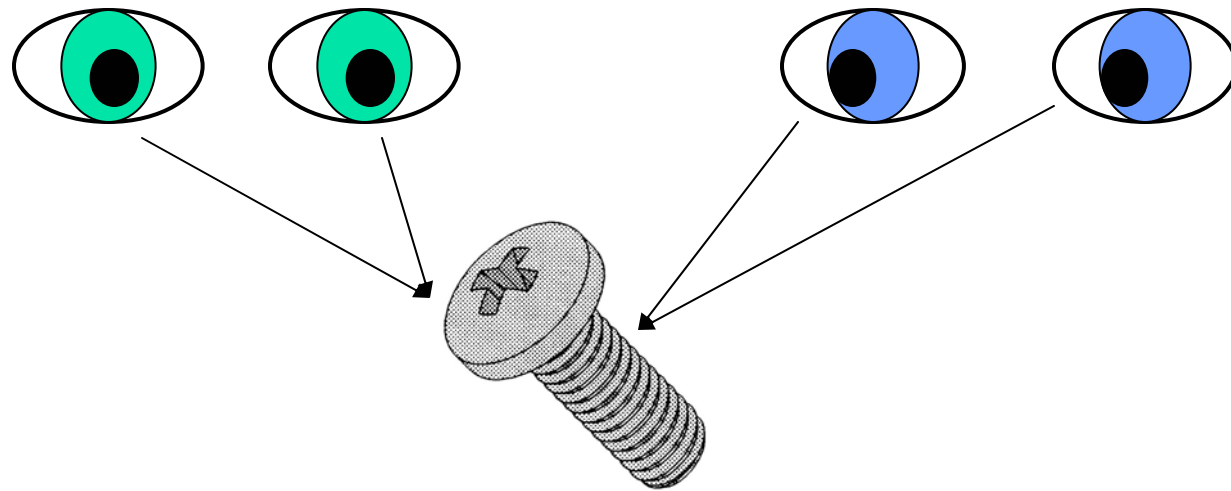

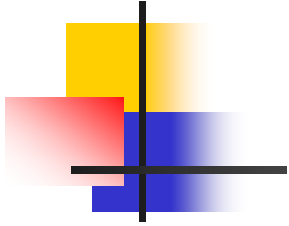

"ZERO DEFECT PARTS"

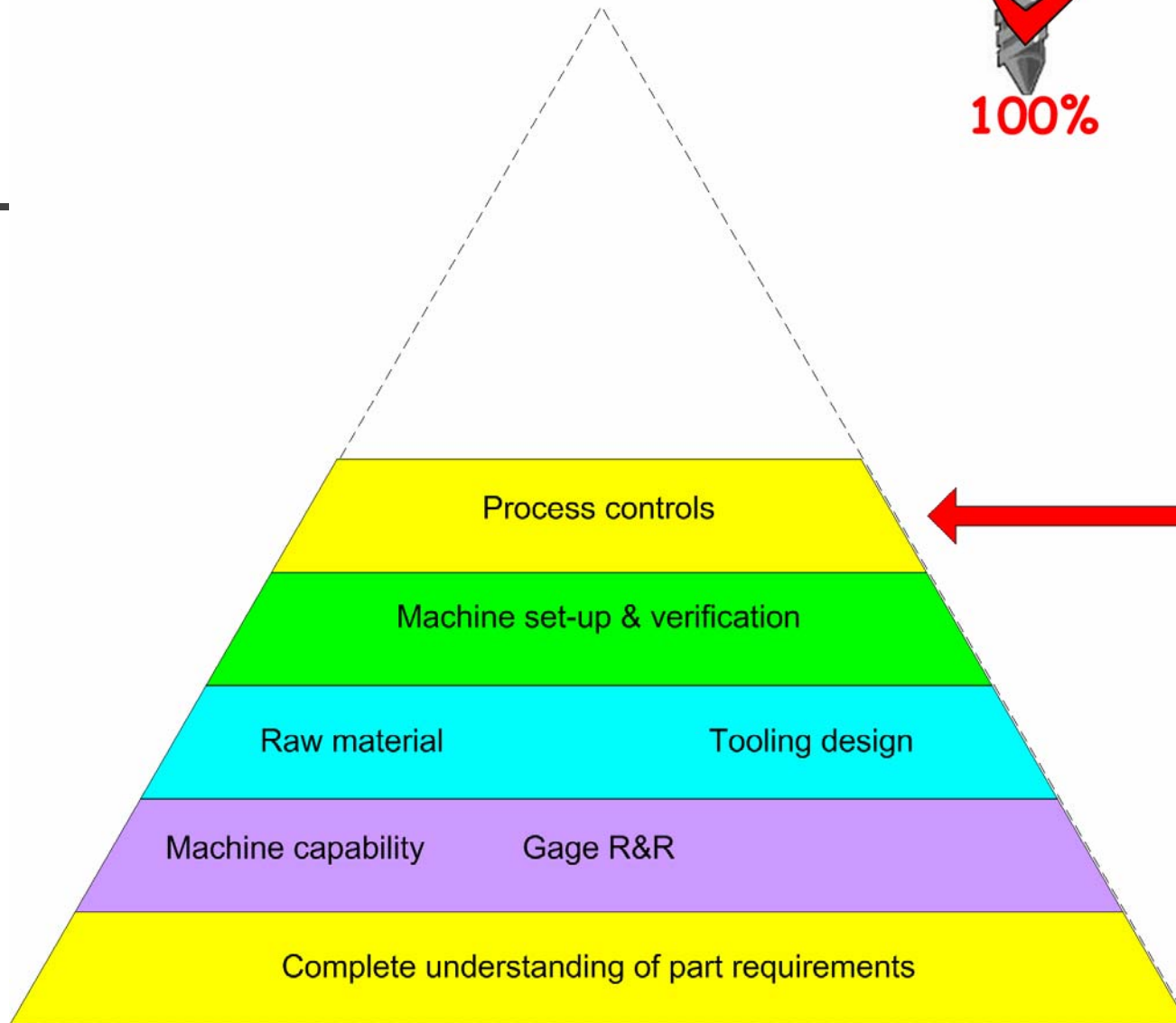

Process Capability

- The **Cpk** target should be **2.00**.
- This will yield not more than **3.4** discrepant parts per million.
- This is **+ / - 6 Sigma**.



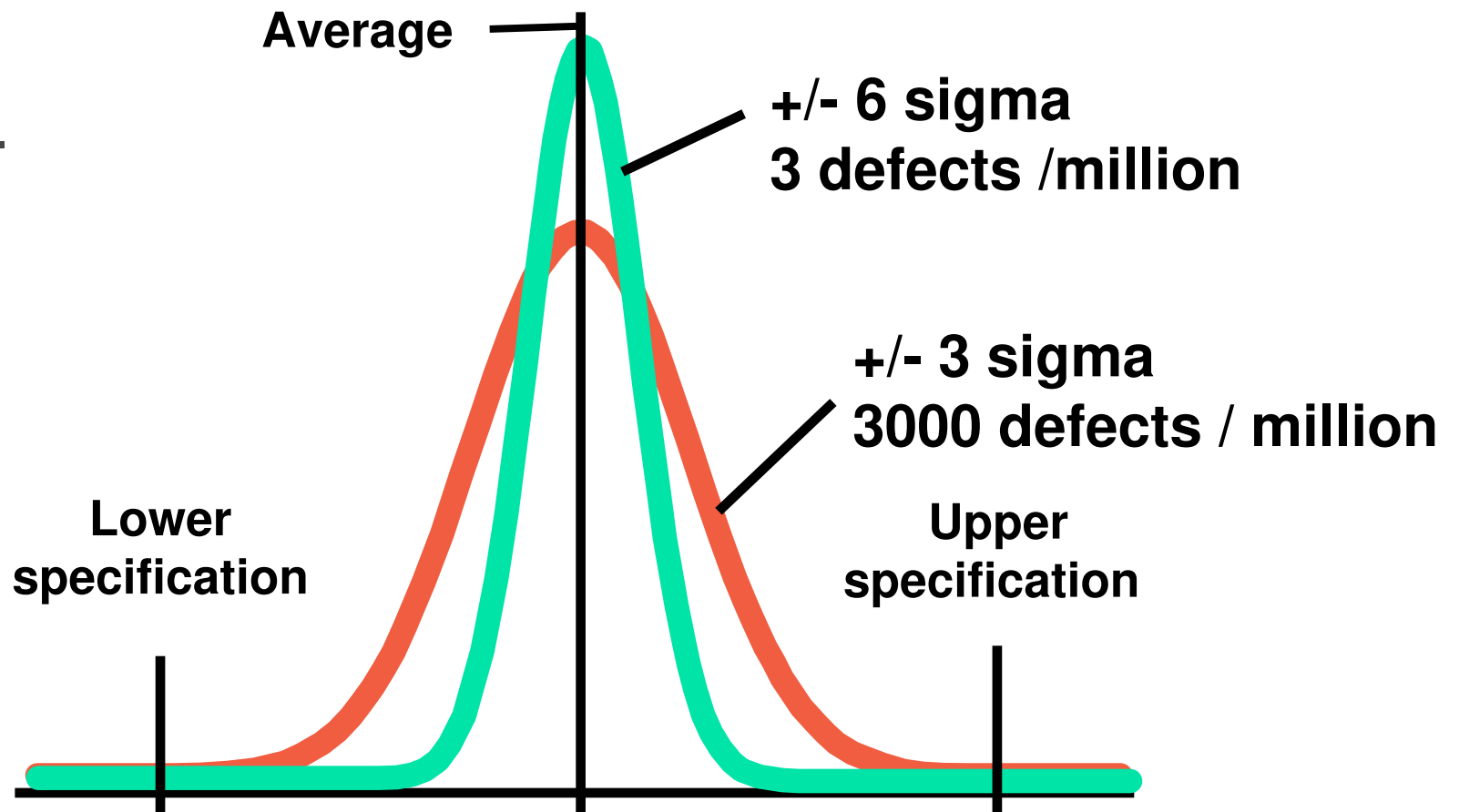
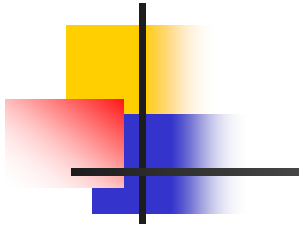

Process controls are essential for consistent production!

- Use “process monitors” on all equipment.

What does the **equipment** indicate (not the part)?

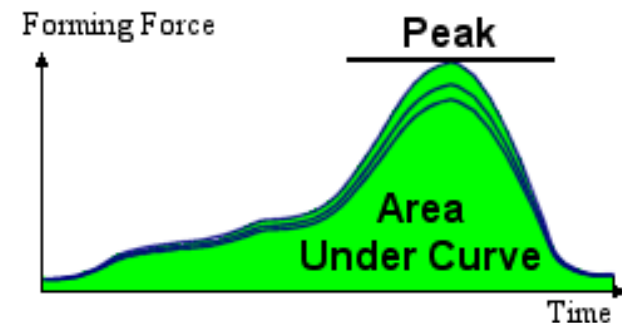

Process controls are essential for consistent production!

- Statistical Process Control (SPC):
 - Monitor “**mission critical**” features.
 - Monitor “**free flow**” features.

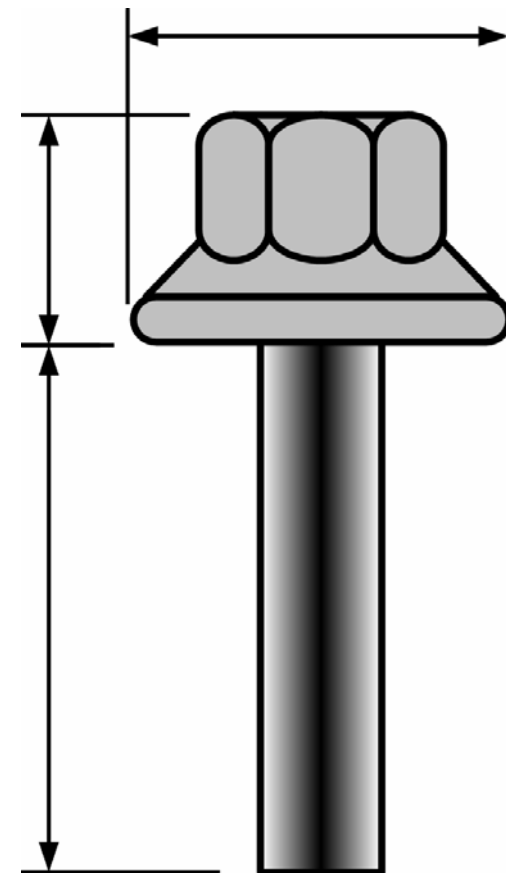

Process controls are essential for consistent production!

- Statistical Process Control (SPC):

Use **computerized** collection system!

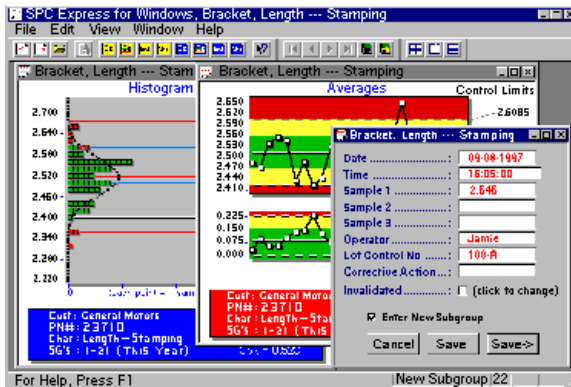

Shipping "ZERO DEFECT PARTS" by Joe Greenslade

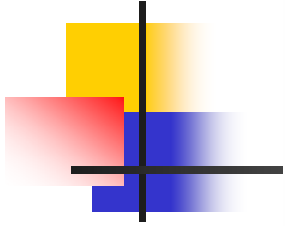

"ZERO DEFECT PARTS"

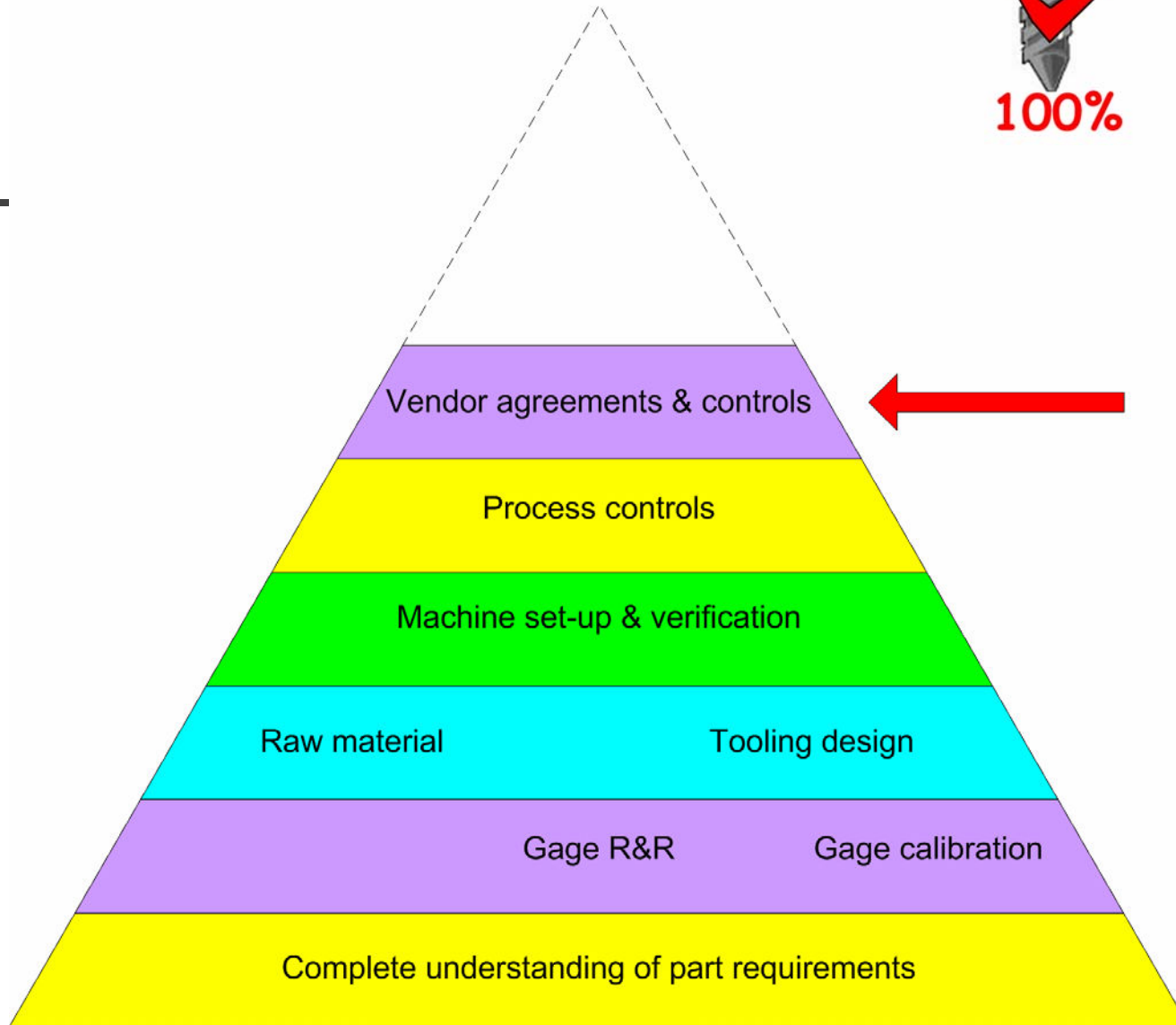

Vendors are critical to shipping consistent parts!

- Have thorough requirement **agreements.**
 - Logical **SPC**
 - **NO CONTAMINATION!**
How accomplished?
 - Acceptance criteria
- **Single vendor** with ISO 9000 registered quality system

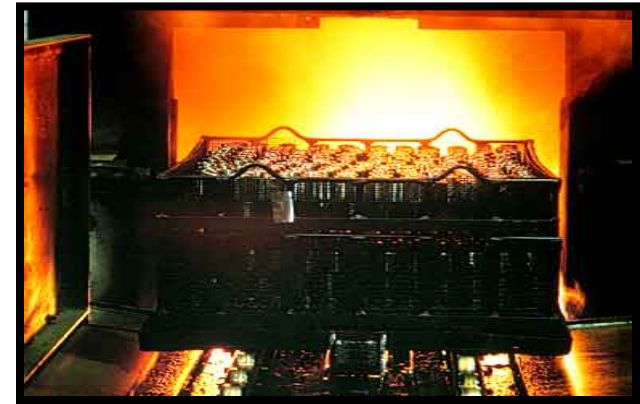

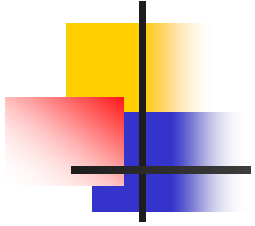

"ZERO DEFECT PARTS"

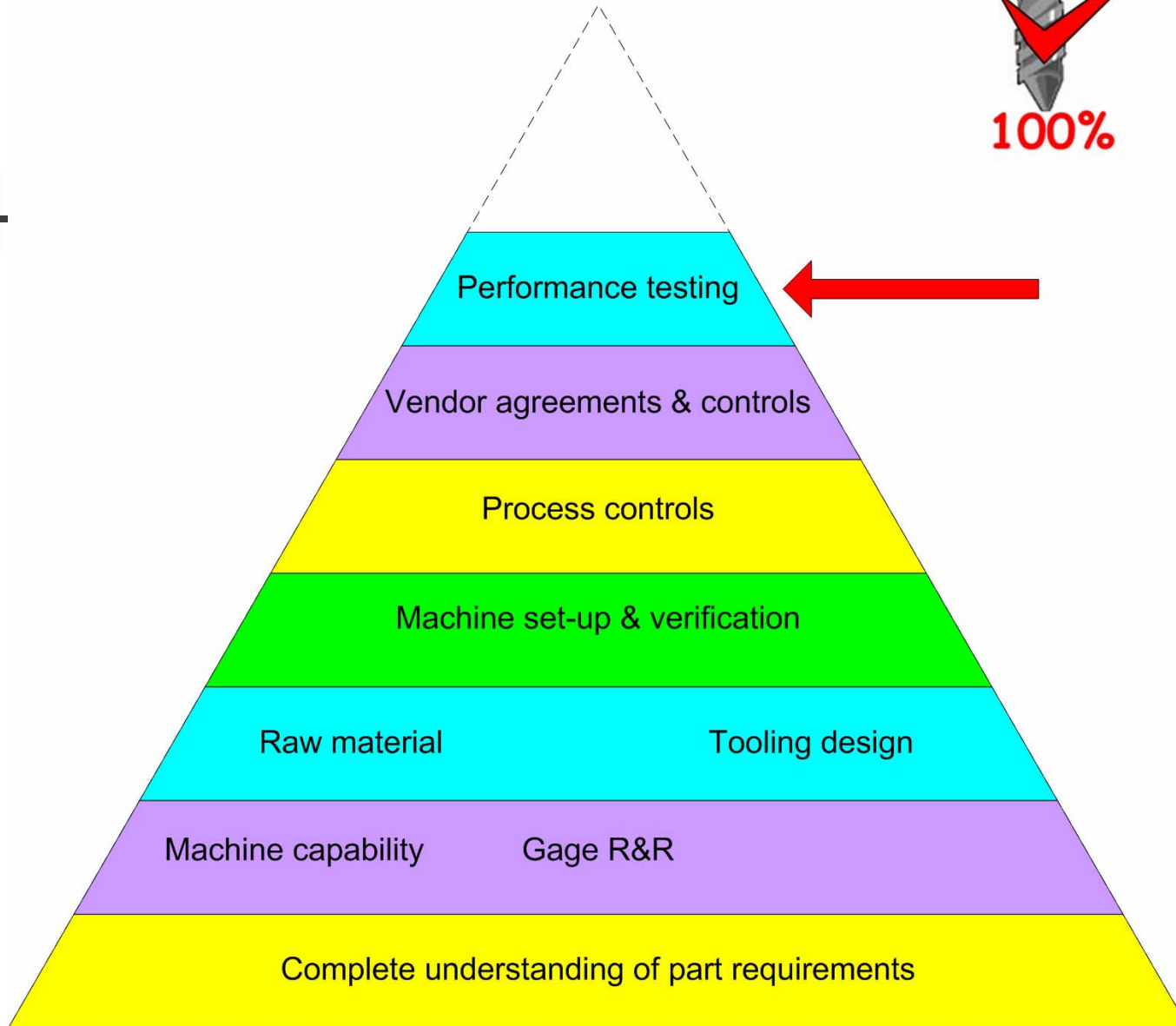

All performance criteria must be met to
ship “**ZERO DEFECT PARTS**”!

- **Understand requirements** & acceptance criteria
 - Strength
 - Torque-tension
 - Drive torque
 - Corrosion resistance
- Perform 30 piece test and **evaluate Cpk.**

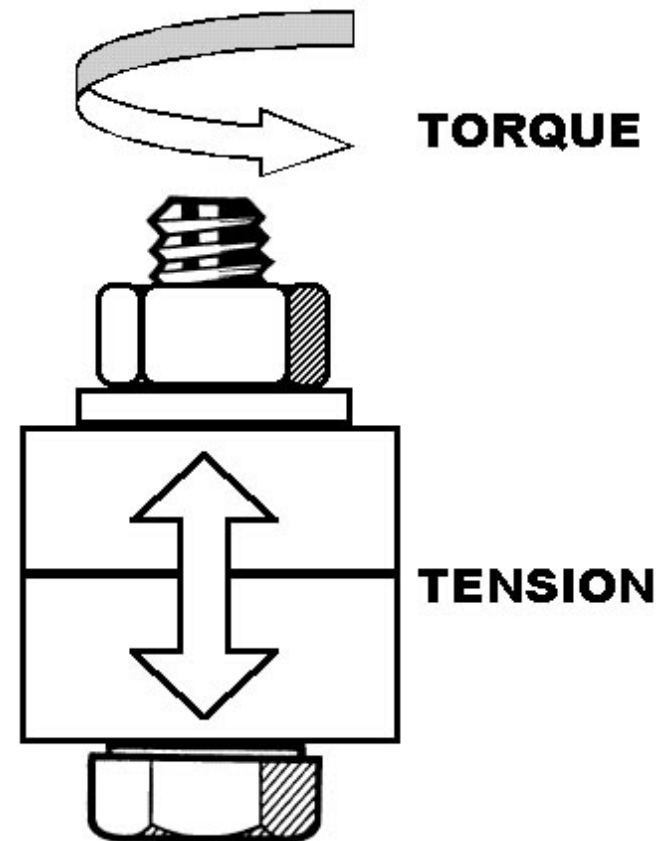

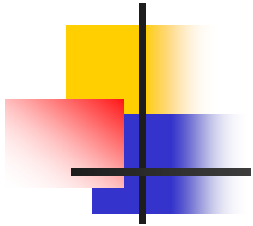

"ZERO DEFECT PARTS"

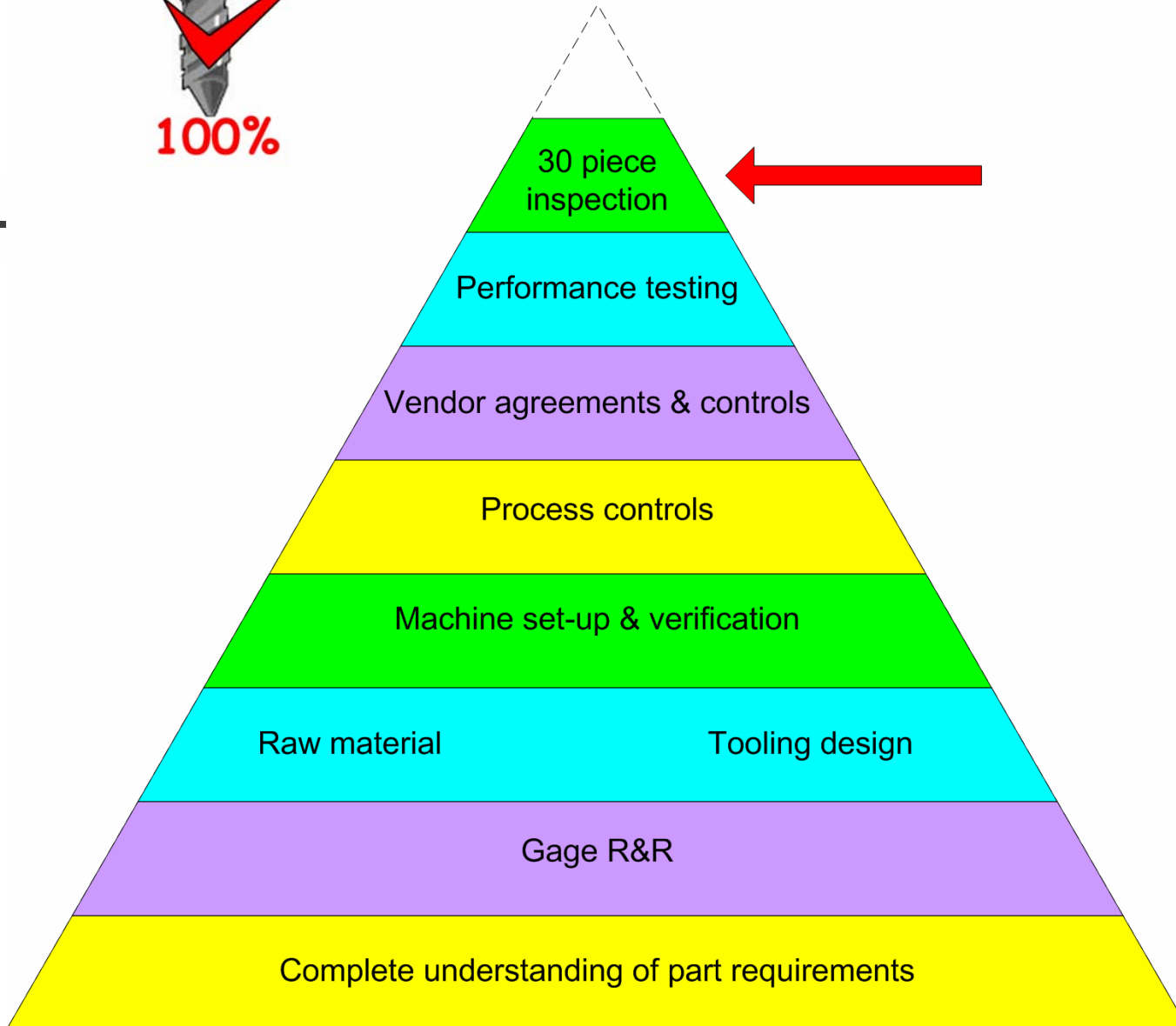



Perform **Cpk** analysis of “**mission critical**” features to make logical sorting decisions.

- Inspect **30** samples.
 - Random samples!
 - One continuously processed lot!
- Calculate **Cpk** on every selected feature.
 - $Cpk = 1.00$ (3 sigma) will yield 3000 defects/million.
 - **$Cpk = 2.00$** (6 sigma) will yield **3.4** defects/million.

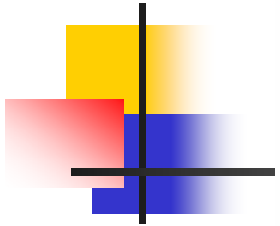

"ZERO DEFECT PARTS"

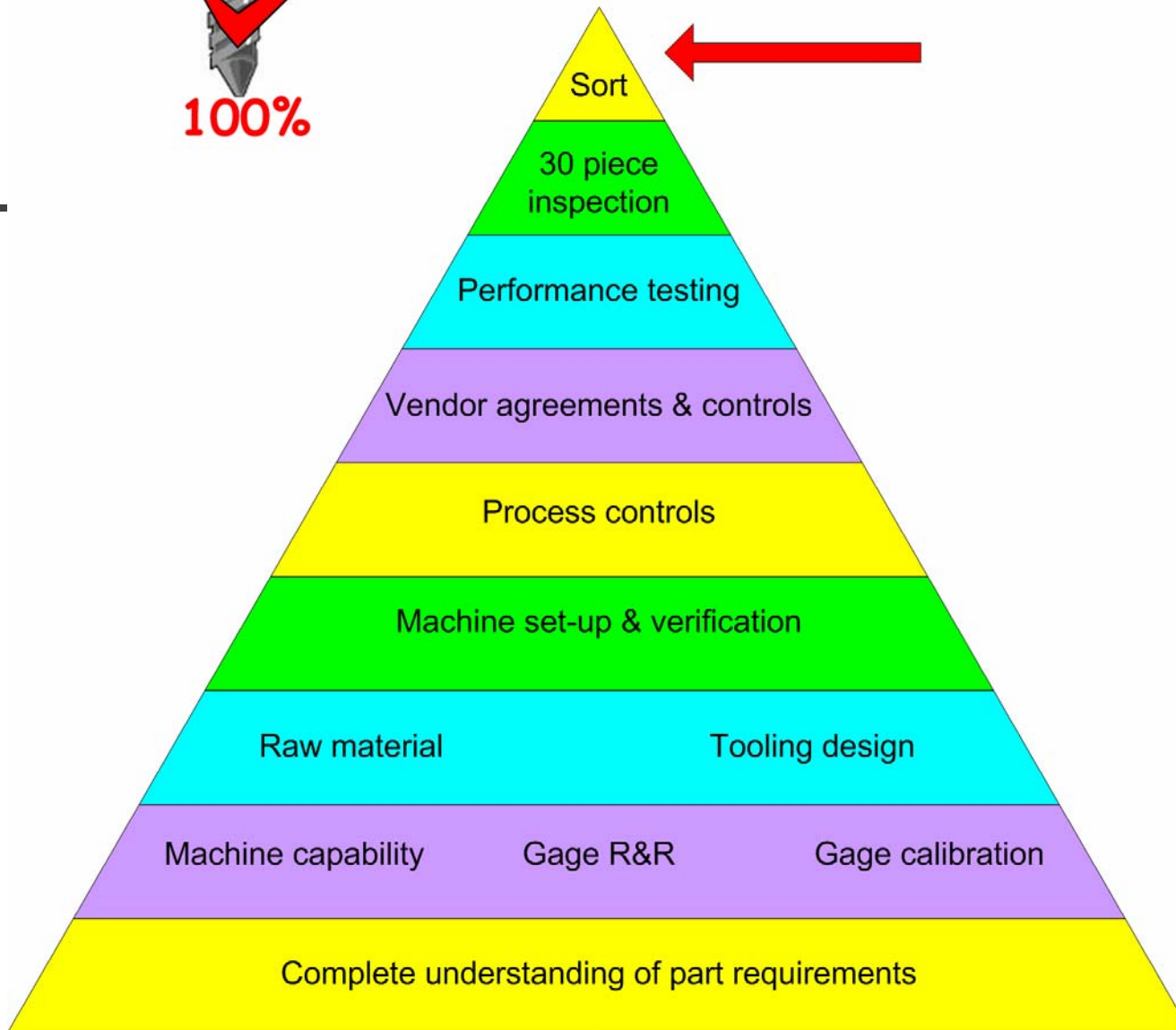

“ZERO DEFECT PARTS” require sorting!

- **Roller sort ALL parts** prior to shipping.
 - 80% of sorting is to remove foreign material.
 - Rollers remove most types foreign material.

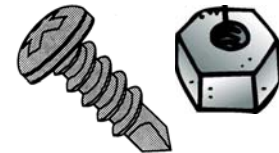
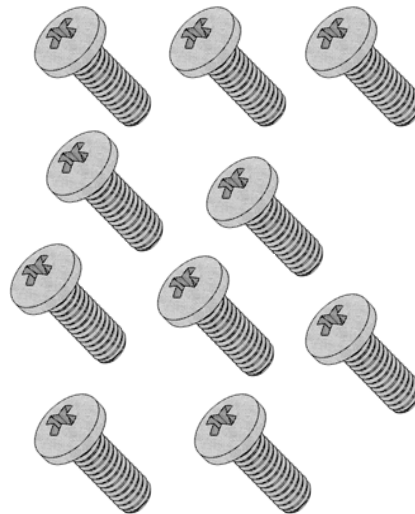

“ZERO DEFECT PARTS” require sorting!

- Sort “**mission critical**” features with a **Cpk greater than 6 sigma**.
 - Use laser, vision, sonic or other technology as appropriate.

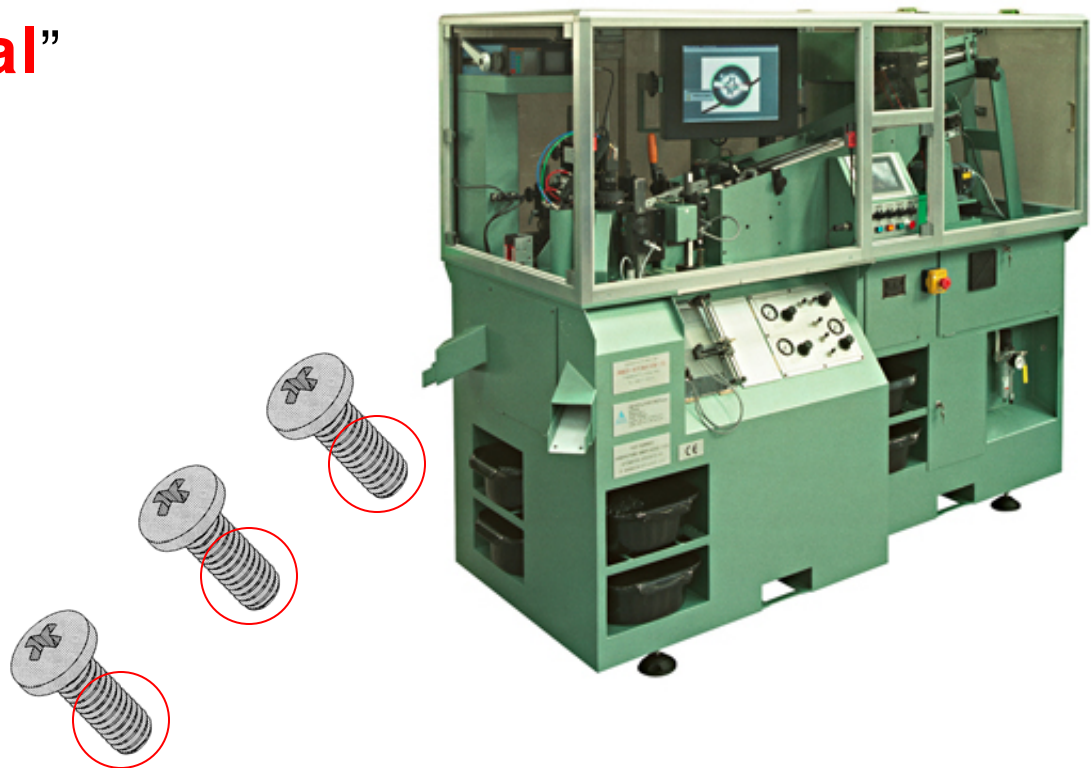

Shipping

“ZERO DEFECT PARTS”

- Requires:
 - A thorough **plan**
 - An approach based on **logic**
 - An extensive use of **statistics**
 - Flawless **execution** of the plan

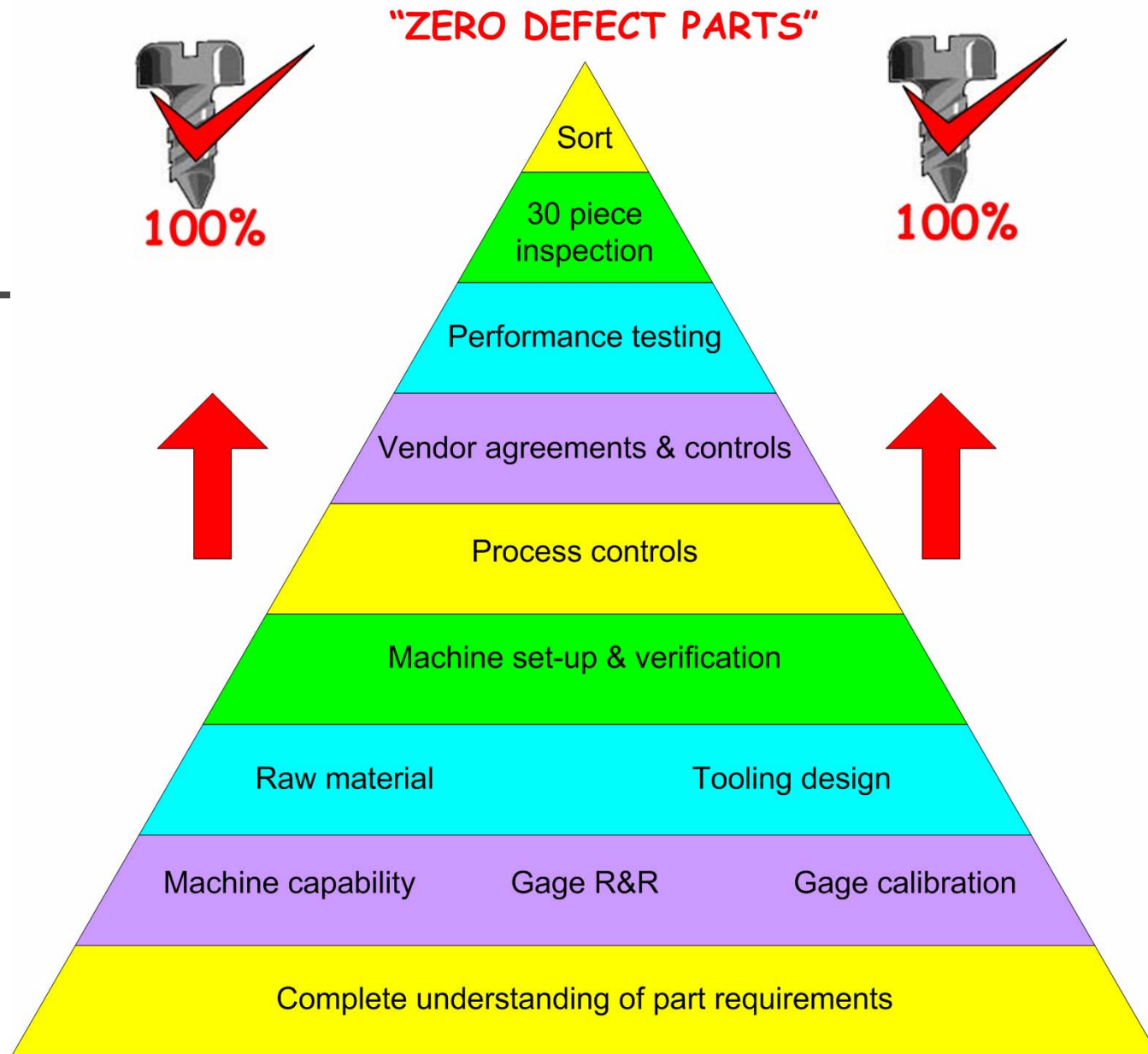
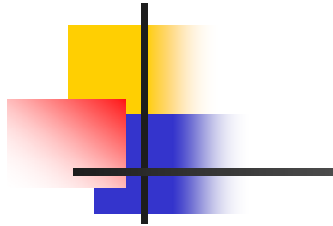

The path to shipping "ZERO DEFECT PARTS"



Every supplier wanting to ship
“**ZERO DEFECT PARTS**” needs a
6 Sigma Black Belt on staff!

- **Six Sigma Academy**
Scottsdale, AZ
480.515.9501
- **Cleveland State University**
Scott Darpel
216-233-3271
- **Uniworld Consulting**
San Antonio, TX
210 798 8888
- Four weeks of training
- Major project relevant to employer
- Cost range:
\$12,000 to \$42,000

Contact Information

- **Joe Greenslade**
- Greenslade & Company, Inc.
- 2234 Wenneca Avenue
- Fort Worth, Texas 76102
- 817-870-8888
- 817-870-9199 Fax
- E-mail: greensladeandcomapny@sbcglobal.net
- Web site: www.greensladeandcopany.com

